



H250 M40

The modular variable area flowmeter



KROHNE

▶ measure the facts

- Secure, cost-effective measurement and indication, even without power supply
- Modular, can be expanded up to FOUNDATION™ fieldbus
- A device that meets all global Ex requirements
- Sturdy, closed tube design for high resistance to pressure, temperature and medium





KROHNE – Measure the facts

Welcome to KROHNE. As a leader in process measuring technology, we're at home in a wide variety of industries worldwide. The name KROHNE has stood for **innovative and reliable solutions since 1921**. The company now offers a whole spectrum of instruments for **flow, level, temperature and pressure measurement as well as process analysis**. Our portfolio is rounded out by comprehensive services and consulting.

Cost-effective and reliable variable area flowmeters are the first choice for the applications where a local indication is required to guarantee the redundancy of a measurement and the safety of a plant. And it is especially in **industries with a safety as a key factor**, e.g. nuclear sector – where our devices are put to the test in comprehensive test programs in terms of capability and suitability, that this **reliability has been appreciated for over 30 years**.

With H250 M40 **we drive forward proven variable area technology** to set the benchmark in the market.

Proven quality from KROHNE

From **universal to one-of-a-kind**: KROHNE's H250 variable area flowmeters cover the entire range of requirements in the process industry.

At KROHNE, the modular device design of the H250 M40 combined with a **flexible production** structure form the basis for application and customer specific versions.

As with every KROHNE variable area flowmeter, you can count on reliability and repeatability. Each device is **individually calibrated** for the respective application. And the robust metal version – available in a variety of materials – provides a high degree of resistance to pressure, temperature and medium.

Automated welding processes with **radiographic inspection** and **surface crack detection** as well as other quality assessments such as material certificates, **pressure, leak and hardness testing**, all under the control of a seamless quality management system, form the basis for the devices being authorised for use in areas where safety is critical such as chemical plants and nuclear power stations.



Typical applications:

- Measurement of small amounts of chemicals, additives or process gases
- Nitrogen inertisation
- Injection of corrosion and scale inhibitors
- Sealing gas monitoring on compressors
- Coolant and lubricant supply
- Protection against dry running of pumps
- Process water or air supply

Application-oriented and always ready for new tasks

Modularity of electronics

The H250 M40 is **purely mechanical in design** and this forms the basis for its flexible uses. **Additional electronic modules** can be added or replaced at any time, making it possible to **scale the functionality** at will. This way the device adapts easily to any changing requirements.

Anything is possible, **from analogue** flow measurement without auxiliary power to **digital integration** into a fieldbus system.

Simply screw off the cover, insert the module until it clicks, screw the cover back on and that's it. There is **no need for tools or to interrupt the process** for the functionality to be scaled at will. It is just as easy to replace the measuring scale in the event of a change in application.

It couldn't be easier.

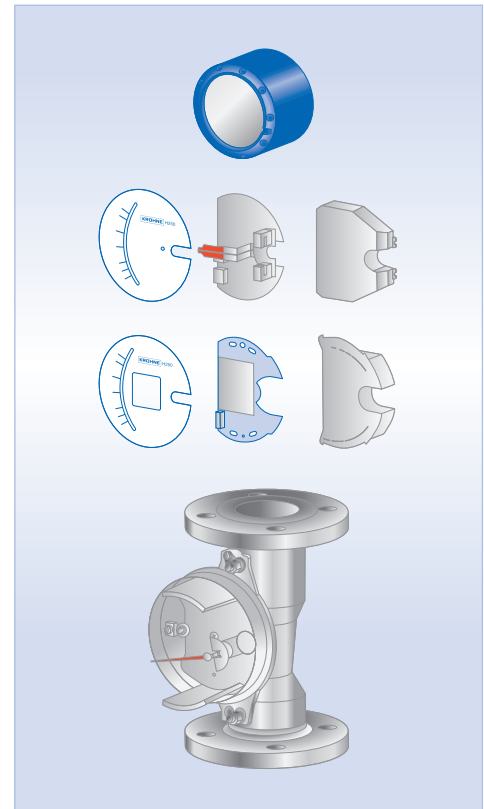

Electrical options

Limit switches	
	<p>3 versions:</p> <ul style="list-style-type: none"> • 2-wire NAMUR contact as per IEC 60947-5-6 • 3-wire transistor output 10-30 VDC • Potential-free reed switch
2-wire sensor module with 4...20 mA current output	
	<ul style="list-style-type: none"> • 4...20 mA for 0...100% flow • Can be combined with limit switches • 14-30 VDC power supply • HART® 7 certified communication • Internal interface to extension modules • Simple loop-check at push of button
Totaliser with pulse output, limit switches and LCD	
	<ul style="list-style-type: none"> • Counter module with graphic display to indicate flow, counter reading, additional information and operating menu • Power supply via sensor module • Operation and parameter setting via internal microswitch or externally using a bar magnet
Fieldbus communication	
	<ul style="list-style-type: none"> • PROFIBUS® PA or FOUNDATION™ ITK 6 fieldbus • Power supply for entire device from 2-wire bus (16 mA current consumption) • Direct bus communication without additional converter

The package for hazardous areas

H250 M40 from KROHNE offers a **universal Ex-design** across a wide range of usage zones and protection types.

All electronic components are designed **intrinsically safe and non-sparking** and can be used in areas that are explosive due to the presence of gas or dust. As an option, the same components, featuring a **safety housing**, can be installed as explosion proof devices. One device can thus accommodate the different regional explosion protection strategies.

H250 M40 is **ATEX-, IECEx- and FM-approved** for the USA and Canada and also according to **NEPSI** for China. In addition, the measuring device also features other local approvals such as **INMETRO, CCOE/PESO, KGS and EAC**.

Whether it's intrinsically safe or explosion proof – the devices are designed as **IP66/IP68** or **NEMA 4X/6** as standard. An **IP69K** version is also available on request.

Intrinsically safe electronics

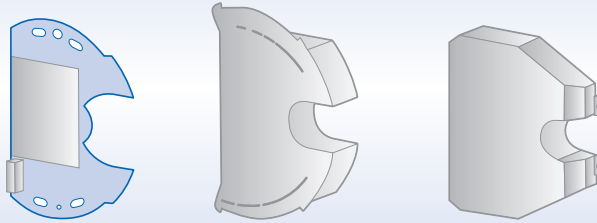

Explosion proof housing

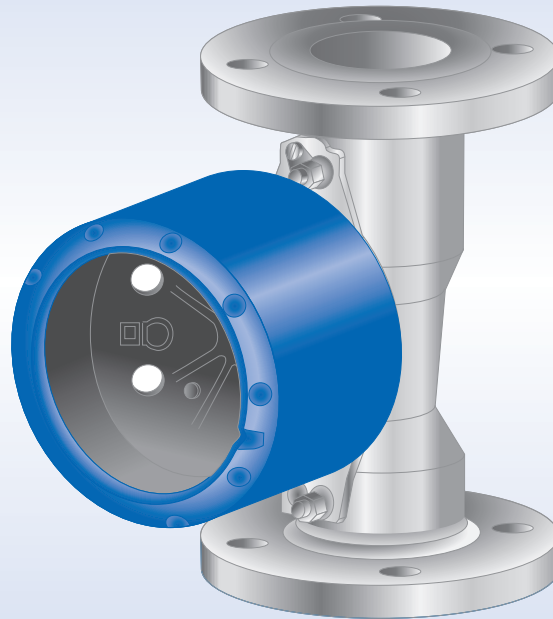



H250 M40R

Robust design for harsh process conditions

The measuring principle allows for a **robust, closed tube design without sensor feedthrough**, as the height of the float is transferred to the indicator by way of a magnetic coupling. This enables **high pressure versions** that can withstand up to 900 barg; 13,000 psig.

All wetted, pressurised parts are made as standard of 1.4404/316L and 1.4401/316 dual certified stainless steel and meet the requirements of the **NACE MR0175/MR0103** standard. To guarantee the longevity of the device even with chemically harsh products, it is possible to use special materials such as **Hastelloy®, titanium, Monel®, 6Mo, Inconel®** etc. in production.

In addition, the H250C M40 is also available with a **PTFE liner** for applications involving aggressive acids and bases.

Special indicator variants for extreme operating conditions

With the **indicator housing made of stainless steel**, the H250 M40R withstands attacks from salt fogs and contaminated precipitates. It can be reliably used in corrosive atmospheres and is perfectly suited for use in spray water zones, such as in the food and beverage industries.

Unique to date: The indestructible stainless steel housing is also available on request in an **explosion**

proof version for use in hazardous areas.

As a **high-temperature variant**, the H250 M40HT measuring device is suitable both for very high product temperatures up to +400 °C; +752 °F as well as cryogenic applications down to -200 °C; -328 °F. The increased distance between the measuring tube and the display makes it easier to insulate the measuring tube.



Hygienic design for use in the food and pharma industries

The H250F M40 is a variable area flowmeter with hygienic design for food and pharmaceutical applications. **FDA, EC1935 and GB4806 compliant materials** meet strict hygienic and legal regulations. A design with **no dead spaces or stagnation zones** as well as pickled and optional **electropolished surface** of the wetted parts with a surface roughness $Ra < 0.8 \mu m$ make it difficult for deposits to settle and facilitate proper cleaning.

The outstanding properties of the H250F M40 are used in the pharmaceutical industry in areas such as ultrapure water plants and in the food industry e.g. for cream measurement.



The expanded measuring range provides more process information

Depending on the technology, the standard **measuring range span** of the H250 M40 is **10:1**. As an option, it is possible to **refine the measuring range span** – and this is worldwide unique for measuring devices in this category – to **100:1**. This way the otherwise necessary additional measuring devices for small quantities are no longer necessary.

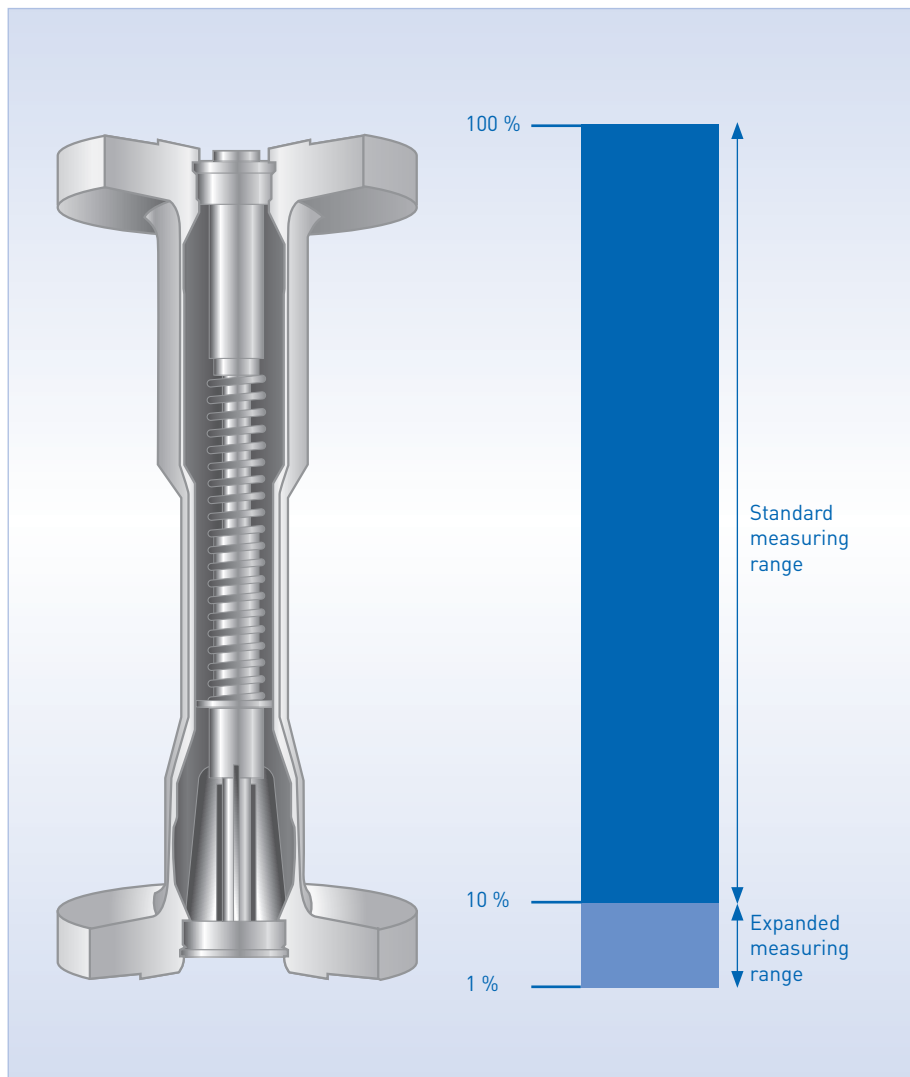

The right solution for any installation direction

Typically, variable area flowmeters are installed vertically in rising pipes and the product must flow through them from bottom to top. This can lead to considerable expense.

The H250 M40 measuring device on the other hand offers you freedom in terms of design as unique versions **can be used for horizontal or even descending pipes**.



H250H M40



H250U M40

Free choice of process connections

Thanks to a **wide variety of process connections** – common flange connections in accordance with DIN, ASME and JIS, male and female threads as well as clamp connections – this device is available to all sectors of industry.

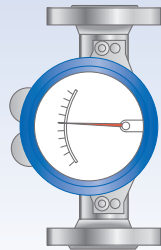

Flange

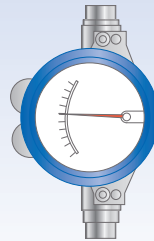

Female thread

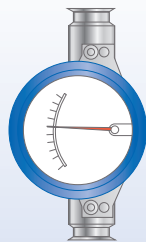

Clamp

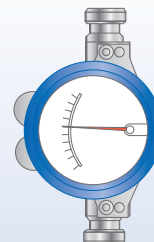

Male thread

The cost-effective and reliable all-rounder

Like all members of the H250 product family, the H250 M40 features the advantages of variable area technology. It guarantees **reliable and precise flow measurement** and provides a high degree of **application reliability**, even with very low flow rates. This is maintained through excellent long-term stability.

The H250 M40 measuring device is all-purpose, especially for **applications with low flow rates**. It is suitable for the measurement of **gases as well as conducting and non-conducting liquids**, even those that are highly viscous. Thanks to the modular design of the indicator, it can even be used where there is **no connection to the power supply**, or where this is difficult but it can also be integrated into any type of

process control or monitoring system. It can be upgraded at a later date simply by **adding modules** and there is no need to replace the existing measuring devices.

User-friendliness was the top priority for KROHNE when developing the H250 M40. Following **simple mechanical installation and start-up** with a electrical connection if applicable, the device is immediately ready to use and it is good for long-term maintenance-free operation.

Economical all the way: High flexibility as well as **low purchase and operating costs** make the H250 M40 variable area flowmeter a cost-effective all-rounder!



CT30
73FE



CT30
75PI



KROHNE

Variable area measuring device family from KROHNE at a glance

Metal devices

- For extreme process conditions
 - High/low temperatures
 - High pressures
 - Aggressive products
- Limit switches, current output, counters and communication possible



H250 M40
The standard device for the process industry, explosion proof or intrinsically safe



DK32, 34, 37
With mechanical or electronic display and dosing valve for precise adjustment of small flow rates

Glass devices

- Very reasonably priced
- Product visible
- Up to max. 10 barg; 145 psig and +100 °C; +212 °F
- Change of glass possible
- Optional: limit switches



VA40, 45
All-purpose flowmeters with various
process connections

DK46, 47, 48, 800
Small, compact purge meters with valve

Technical data

	Standard	Option
Wetted material	1.4404/316L and 1.4401/316 dual certified stainless steel (NACE MR0175/MR0103-compliant)	Stainless steel electropolished for food and pharmaceutical industry, Hastelloy®, titanium, Monel®, 6Mo, Inconel®, PTFE liner
Process connections	EN/ASME/JIS flange DN15-DN150	Screw connection, clamp, welding ends, threaded connection, aseptic connections
Display housing	Aluminium die casting, coated	Stainless steel
Ex-design	Intrinsically safe: Ex-i (IS) Non-sparking: Ex-nA (NI)	Explosion proof: Ex-d (XP) Dust ignition proof: Ex-t (DIP)
Electronics features	Measurement and indication without power supply	Modular: <ul style="list-style-type: none"> • Limit switches (NAMUR, transistor, reed) • 2-wire current output 4...20 mA HART® 7 • FOUNDATION™ ITK6 fieldbus/PROFIBUS® PA • Totalizer with digital display and pulse output
Mounting position/direction of flow	Vertical/from bottom to top	Horizontal/from left to right or right to left Vertical/from top to bottom
Error limit according to VDI/VDE3513-2 (qG=50%)	1.6%	Precision calibration on request
Measuring span	10:1	100:1
Accessoires	<ul style="list-style-type: none"> • Magnetic filter, if the medium contains particles which can be magnetically influenced • Float damping, for pulsating flows or low operating pressures (particularly when measuring gases) • Pointer damping for easy reading of measured value • Heating jacket for measuring cone 	



Operating conditions

Products	Clean, non-abrasive liquids and gases as well as liquefied gases, e. g. water, chemicals, oils, lubricants and corrosion inhibitors, distillates, air, process gases, purge gases
Measuring ranges liquids	10 l/h-120 m ³ /h; 5-32,000 GPH
Measuring range gases (referenced to atmospheric operating pressure)	500 l/h-2800 m ³ /h; 25-100,000 SCFH
Process temperature	-200...+400 °C; -328...+752 °F
Process pressure	Up to 900 barg; 13,000 psig, higher pressures on request
Ambient temperature	-40...+120 °C; -40...+248 °F (+70 °C; +158 °F for electronic modules)
Housing protection	IP66/68 or NEMA 4X/6, IP69K on request
Installation recommendations	In accordance with VDI/VDE 3513 sheet 3

KROHNE – Process instrumentation and Measurement solutions

- Flow
- Level
- Temperature
- Pressure
- Process analysis
- Services

KROHNE Messtechnik GmbH
Ludwig-Krohne-Str. 5
47058 Duisburg
Germany
Tel.: +49 203 301 0
Fax: +49 203 301 103 89
info@krohne.com
www.krohne.com

KROHNE